

FORD PICKUP & VANS

1985
1-11-96

PACKING LIST 7079

1	7063-1 Compressor Mount (Front)	4	3/8" NC x 1" Bolts
1	7063-2 Compressor Mount (Rear)	2	3/8" NC x 1 1/4" Bolts
2	7079-1 Coil Brackets	3	3/8" NC x 1 1/2" Bolts
1	9555150 or 3551501 C/S Pulley	1	3/8" NC x 1 3/4" Bolt
1	2" Eccentric	2	3/8" NC x 2 3/4" Bolts
1	Standard Idler Pulley	2	7/16" NC x 1 1/2" Bolts
1	1" Shoulder Bolt	1	1/2" NF x 1" Bolt
1	1/8" Idler Spacer	4	3/8" NC Nuts
1	1/2" Idler Spacer	1	7/16" NC Nut
1	3/16" Mount Spacer	11	3/8" Lockwashers
1	7/32" Mount Spacer	2	7/16" Lockwashers
1	1 3/16" Mount Spacer	2	M10 x 1.5 x 30 Bolts
1	17520 or 9520 Belt	2	M10 x 1.5 Nuts
2	M10 Lockwashers	8	10" x 32" Nuts
		4	10" x 32" x 1 1/2" Bolts

INSTALLATION INSTRUCTIONS

Use Sanden 508 or Seltec TM-15, or TM-13HD Compressor
With 5.25" Double A Groove Clutch

1. Disconnect battery.
2. Remove fan, fan shroud, water pump pulley and power steering belt.
3. Remove power steering pump pivot bolt and discard OEM spacer between pump and head.
4. Remove coil if mounted on front of head. Remove and discard OEM coil bracket.
5. Using front compressor mount and schematic as a guide, remove necessary bolts from water pump.
6. Loosely install rear compressor mount to engine, paying close attention to the power steering pump bracket. Check schematic for proper bolts and spacers to be used on different pump brackets.
7. Loosely install front compressor mount to water pump, using (2) 3/8" NC x 1 1/4" bolts with lockwashers in inside holes. (1) 7/32" mount spacer, (1) 3/8" NC x 1 3/4" bolt with lockwasher in outside hole. On standard steering models, use (1) 3/16" mount spacer on outside hole also.
8. Loosely install compressor, using (2) 3/8" NC x 2 3/4" bolts with lockwasher and nuts in rear compressor trunnion and (2) 3/8" NC x 1 1/2" bolts with lockwashers and nuts in front trunnion.
9. Tighten all compressor mount and compressor bolts uniformly and securely.
10. Install coil brackets to coil and attach to compressor, using hardware noted on schematic.
11. Install crankshaft pulley, using (4) 3/8" NC x 1" bolts with lockwashers. Tighten uniformly and securely.
12. Replace water pump pulley, fan assembly and shroud.
13. Install idler assembly, using (1) 2" eccentric, (1) standard idler pulley, (1) 1/8" idler spacer, (1) 1" shoulder bolt, and (1) 1/2" NF x 1" bolt.
14. Replace power steering belt. Adjust to proper tension and tighten securely.
15. Wrap compressor drive belt around crankshaft pulley clutch and idler pulley. Adjust eccentric to proper tension and tighten securely.
NOTE: With a 8 3/8" diameter OEM crankshaft pulley it is necessary to use a 17550 compressor drive belt.
16. Connect battery.

CAUTION: BEFORE RELEASING VEHICLE TO CUSTOMER - Check all Radiator Hoses, Heater Hoses and Oil Lines to be sure there is proper clearance of Compressor, Compressor Mount and Compressor Clutch.

FORD PICKUP & VANS 7079

SUPPLEMENTAL SHEET for POWER STEERING APPLICATIONS

302 -

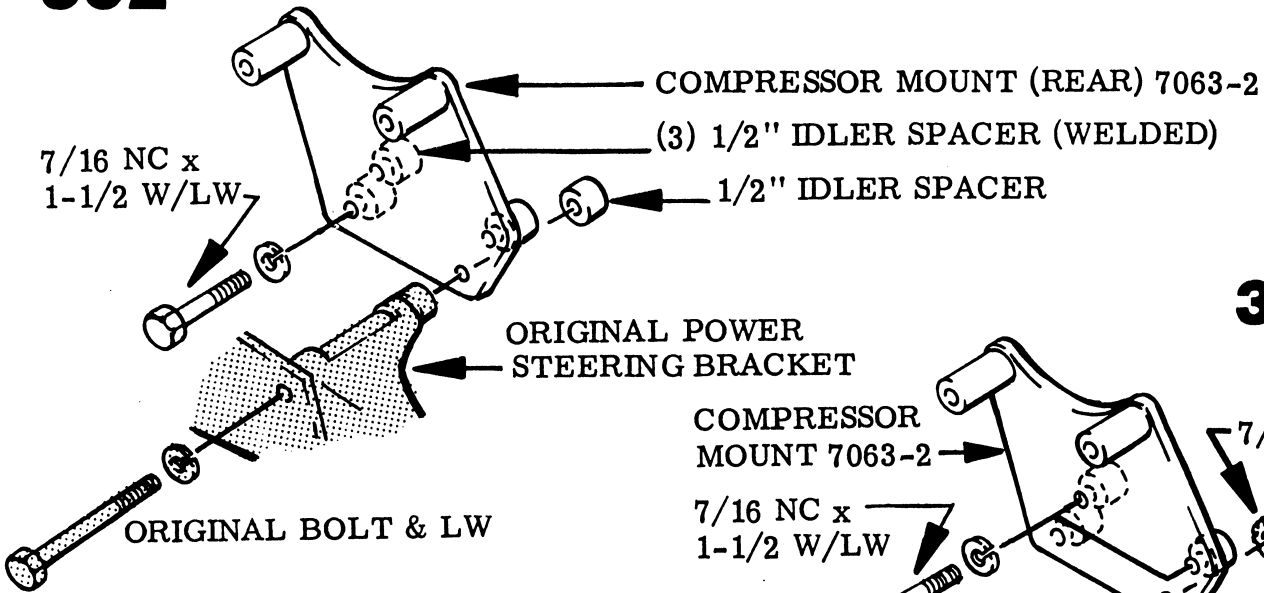

351 -

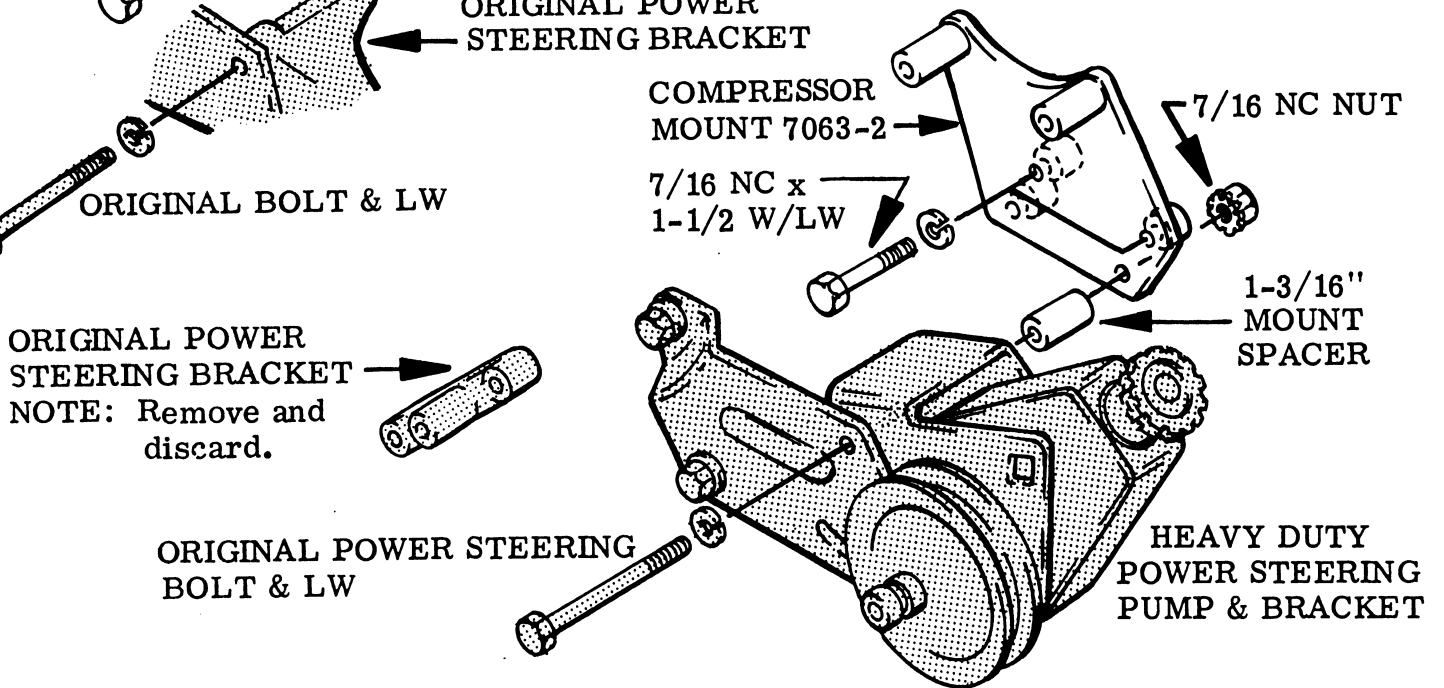

302 -

